

NU-GUARD SC2-P



NU-GUARD SC2-P



Mechanical & Abrasion Protection
Noise Reduction



Self-Closing Sleeving

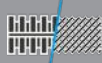

Knitted



PET monofilament
Texturized multifilament



Standard: Black with purple stripe



Low: -40°C (-40°F)
High: 150°C (302°F)



Medium abrasion resistance
Noise reduction >10 dB

PHYSICAL PROPERTIES

Physical properties	Spec	Value
Long term aging (3000h/150°C)	-	pass
Short term aging (240h/175°C)	-	pass
Abrasion resistance	GMW 14327 PSA 96 458 709 99	category 3 class 3
Noise reduction	GMW 14327	class D
Flammability	SAE J 2192	self-extinguishing
Chemical resistance	Resists the majority of chemicals and automotive fluids	

DIMENSIONS

Designation	Nominal Ø (mm)	Functional Ø (mm)
NU-GUARD SC2-P 05	5	4 - 5
NU-GUARD SC2-P 08	8	6 - 8
NU-GUARD SC2-P 10	10	9 - 10
NU-GUARD SC2-P 13	13	11 - 13
NU-GUARD SC2-P 16	16	14 - 16
NU-GUARD SC2-P 19	19	17 - 19
NU-GUARD SC2-P 25	25	20 - 25
NU-GUARD SC2-P 29	29	26 - 29
NU-GUARD SC2-P 32	32	30 - 32
NU-GUARD SC2-P 38	38	33 - 38
NU-GUARD SC2-P 42	42	39 - 42

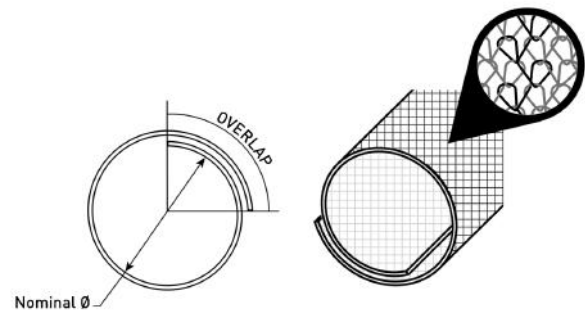

DELFINEN_NU-GUARD SC2-P_EN_v1.8

APPROVALS

Direct:

BMW, Chrysler, Force Motors,
Fiat, Ford, General Motors,
Jaguar/Land Rover, Peugeot-
Citroën, Renault-Nissan, Tata
Motors, Volvo Cars Corp., Yutong

Via Tier-1:

Mahindra, Subaru, Nio

PACKAGING

Coils
Cut lengths upon request